

REVERSE OSMOSIS RO ECO

Reverse osmosis on membrane

It is a membrane process, which allows almost all of the substances present in it to be removed from the water.

The water in the feed is pressurized by a pump which exerts a pressure higher than the osmotic one, obtaining two flows: the permeate, poor in salts and the concentrate with a high salt concentration, due to the accumulation of all the salts which do not have crossed the membrane.

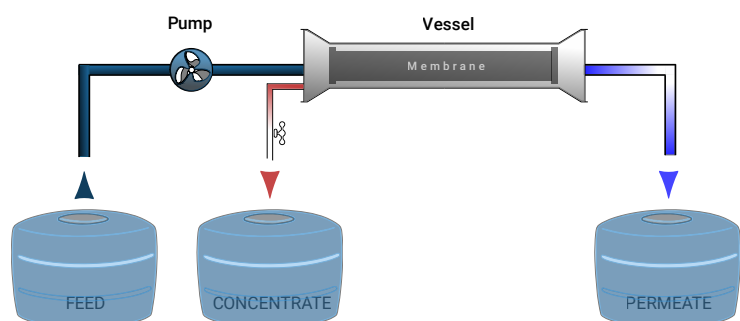

REVERSE OSMOSIS RO ECO

The RO ECO series machines are designed, sized and built with strict quality control procedures and with particular attention to limiting energy and water consumption.

The reverse osmosis units of the RO ECO family produce considerable quantities of purified water with continuous operation in heavy professional uses in the community, industrial, agricultural and technological fields; they can be used in the standard version up to pressures of 30 bar (at 15 °C) using different types of membranes.

The ECO ROs are characterized by considerable robustness, ease of installation, simple operation and easy maintenance accessibility. Their operation is managed with PLC logic and "flushing" is provided at the end of the work cycle, at a programmable intermediate time and every 24 hours of inactivity in order to avoid premature deterioration of the membranes.



REVERSE OSMOSIS RO ECO 24 BE-BS

Standard Equipment

- Supporting structure entirely made of AISI 304 tubular Tig welded stainless steel;
- Piping and low pressure line fittings in PVC-U PN16 and high pressure line in AISI 304 EU;
- Calibratable safety pressure switches for: minimum, maximum and maximum pump pressure;
- 24V automatic valves for power supply and flushing;
- AISI 316 pressurization, remineralization, recirculation valves (if provided);
- 8" membranes;
- Vessels in 8" VTR;
- Hydraulic control panel complete with 5 glycerine bath stainless steel pressure gauges for displaying:
 - IN filtration, OUT filtration, IN membranes, OUT membranes, MAX pump;
- Direct reading flow meters: permeate, concentrate, recirculation (if provided);
- AISI 316L stainless steel vertical multistage pump;
- BIG safety filter, PVC-U multi-cartridge filter;
- Digital permeate conductivity meter with set point alarm and 4 - 20 mA output;
- Management and control framework consisting of:
 - resin container, main switch with door lock device;
 - transformer complete with protections for powering auxiliary circuits;
 - phase control relay;
- PLC with 7" color operator panel on the front of the panel with display of operating states, working hours and remote alarms for low/high pressure/thermal block/high conductivity/low level of dispenser 1 and 2 (with relative audible alarm), thermal , 230 V ON-OFF auxiliary power supplies in the terminal block with work cycle start and provision for tank level regulator;
- motor protection switches; relay for auxiliary management;
- buzzer on the front of the panel for acoustic alarm signalling;

Optional

- 4 BIG filter / AISI 304 or 316 stainless steel multi-cartridge filter
- Dosing pumps for antiscalant and biostabiliser
- Alarm transmission system via GSM
- Soft-start start-up of the pressurization pump
- Double set-point digital conductivity meter
- Double pump on board the machine
- Fiberglass grating
- PVC-U high pressure piping
- 4" and 8" vessels in AISI 304 or 316 steel
- CIP washing group
- HMI 10" touch screen



Water saving



Energy saving



Certified materials



Controlled construction process



Tested operativity



REVERSE OSMOSIS RO ECO 12 AR + WASHING KIT

Legenda

RO	•	→	Reverse Osmosis
ECO	•	→	Series
8	•	→	Number of membranes
UBE	•	→	Type of membranes

Membranes

Type	Saline rejection	Energy saving	Resistance to fouling
Low Energy BE	Good	Optimal	Ordinary
Ultra-Low Energy UBE	Good	Excellent	Ordinary
High rejection Low energy AR-BE	Excellent	Optimal	Ordinary
Low pressure Low fouling BP-BS	Optimal	Good	Optimal
Ultra-low energy Low fouling UBE-BS	Good	Excellent	Optimal
Sea Water AM	Excellent	Good	Ordinary
Sea Water Low energy AM-BE	Excellent	Optimal	Ordinary

Standard technical and hydraulic details

Model	Permeate l/h	Recirculation l/h	Concentrate l/h	Recovery %	Vessel n	Operating pressure bar	Power supply
RO ECO 2 UBE	2400	1500	2900	45	1	10,5	4,0 kW - 400V
RO ECO 3 UBE	3400	1000	2800	55	1	10,5	4,0 kW - 400V
RO ECO 4 UBE	4300	1000	2500	65	2	10,5	4,0 kW - 400V
RO ECO 6 UBE	6100	0	3600	65	2	10,0	5,5 kW - 400V
RO ECO 8 UBE	7300	0	3100	70	2	10,0	5,5 kW - 400V
RO ECO 9 UBE	9000	1000	3900	70	3	10,5	7,5 kW - 400V
RO ECO 12 UBE	12000	0	5100	75	3	10,5	11 kW - 400V

FURTHER SIZINGS ARE AVAILABLE UPON REQUEST

Values referring to the treatment of water with characteristics as per the "Raw water reference parameters" table with variations of $\pm 20\%$

Raw water reference parameters

Parameter	Limit
TDS (Total Suspended Solids)	<2000 ppm
SDI (Sit Density Index)	<3
pH	7,0 - 7,5
Turbidity	0,2 NTU
Temperature of feed	20 °C
Pressure of feed	2,5 - 5,0 bar
Iron without anti-precipitant	<0,01 ppm
Chlorine, Hydrogen Sulphate, Manganese	Absent
Hardness without antiscalant	<5 °f
Micro-biological pollution	Absent

Geometry

Vessel model	(A) Length cm	(B) Depth cm		(C) Height cm
		1 bar	2 bars	
2 elements	340	110	148	204
3 elements	415	110	148	204
4 elements	520	110	148	204
5 elements	620	110	148	204
6 elements	725	110	148	204

Pressure of feed: +2,5 - +5,0 bar
 Temperature of feed: +14 - +25°C
 Environmental temperature: +2 - +40°C

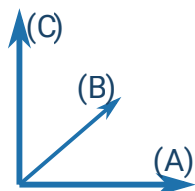

REVERSE OSMOSIS RO ECO 24

Water Panel



It allows the display of the permeate concentrate flow rates, the recirculation (if foreseen) of the filtration and osmotization pressures. It includes pressurization and recirculation needle valves in AISI 316.

Piping in AISI304 and PVC



The permeate line is made of PVC-U and is equipped with taps useful for sampling and checks.

The concentrate line is built in AISI 304 EU, TIG welded.

Pressure switches



The programmable pressure switches allow you to operate safely, preserving the pump and diaphragms. They communicate with the electrical panel and allow the machine to be stopped if necessary.

Pressurization pump



The vertical multilayer pumps, in AISI 304 or AISI 316, are reliable, silent and easy to maintain.

They are sized in such a way as to guarantee suitable pressurization of the water in the feed, tending towards energy savings.

Automatic Valve



The motorized valves, thanks to the commands received from the electrical panel, allow the soft opening and closing of the hydraulic lines. They are also equipped with microswitches to control correct opening and closing.

Membranes



Semipermeable spiral membranes must be appropriately chosen based on the characteristics of the feed water and the characteristics of the water used wants to get.

REVERSE OSMOSIS RO ECO

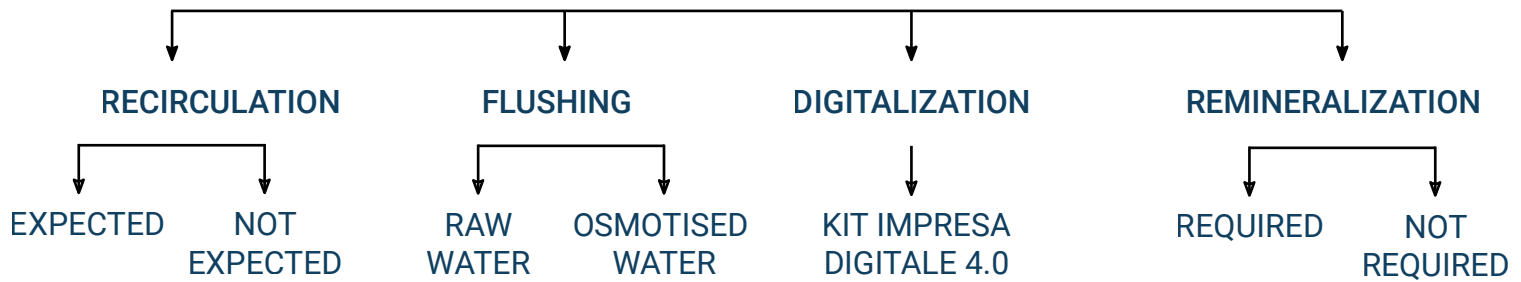

LEGENDA

- | | |
|------------------------------------|--|
| 1. Inlet valve | 13. IN membranes (Manometer) |
| 2. IN filtration (Pressure gauge) | 14. Demineralization |
| 3. Security filtration | 15. Flowmeters |
| 4. OUT filtration (Pressure gauge) | 16. Conductivity meter |
| 5. Automatic inlet valve | 17. OUT membranes (Pressure gauge) |
| 6. Non-return valve | 18. Pressurization valve |
| 7. Press. min. | 19. Automatic flushing valve (with raw/osmotic water) |
| 8. Pressurization pump | 20. Recirculation valve (Recirculation where provided) |
| 9. Press. yes. pump | 21. Remineralization valve (Remineralization) |
| 10. Flow rate adjustment valve | 22. Pressure Transducer (Kit Impresa Digitale 4.0) |
| 11. Press. max | 23. Flow Meter (Kit Impresa Digitale 4.0) |
| 12. Sacrificial anode | 24. Dosing pump (optional) |

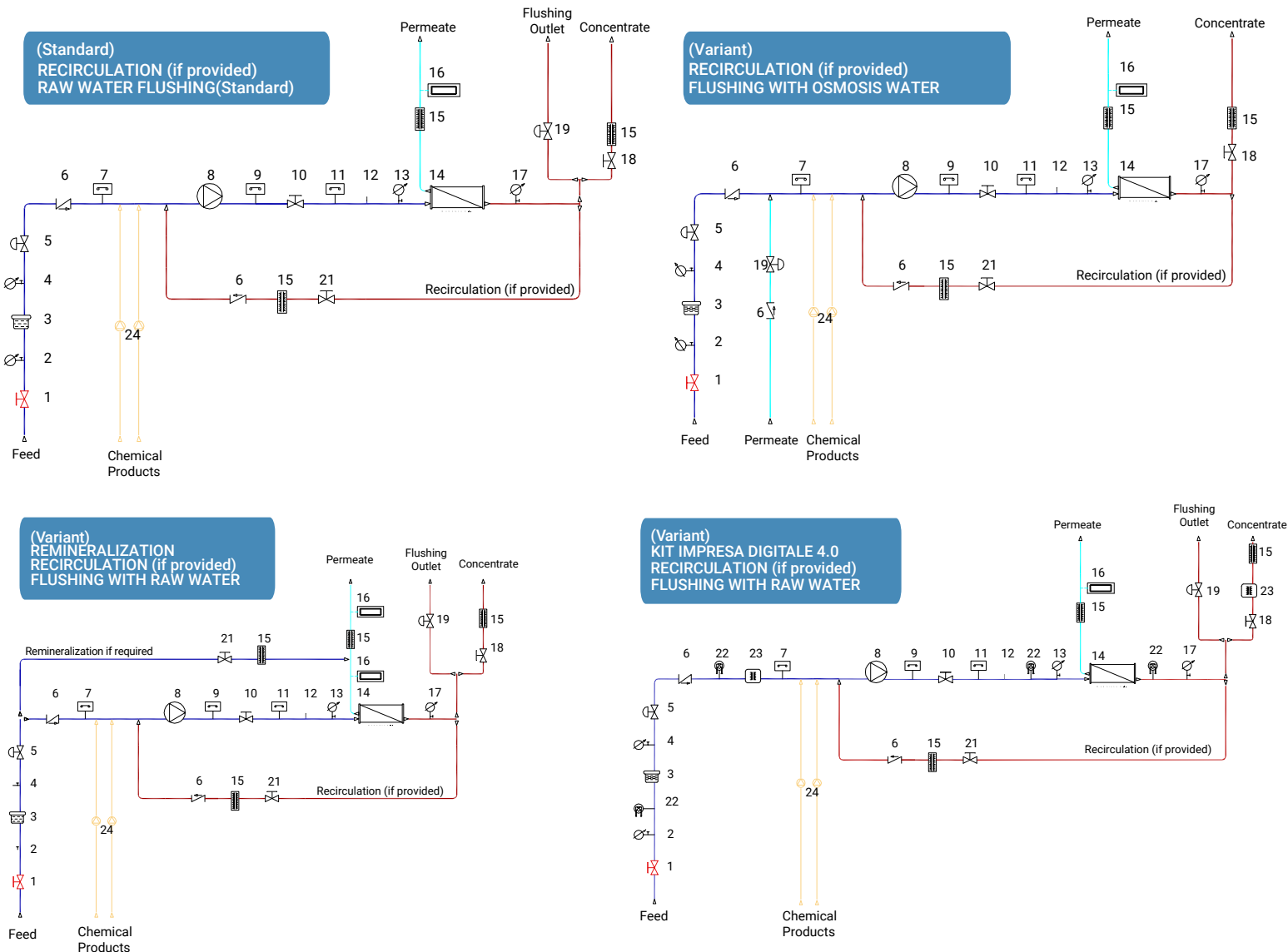

Kit impresa digitale 4.0

The kit makes multiple and advanced additional technological functions available to control and monitor the treatment process and to display the following values on the HMI panel, and therefore on connected remote devices such as PCs or Smartphones (Android/iOS):

a) Instantaneous and total hydraulic flow rates:

- Incoming raw water
- Product permeate
- Concentrate discarded

b) Instantaneous pressures and history:

- IN and OUT Filtration and relative Delta P
- IN and OUT membranes and relative Delta P

It is composed of 4-20 mA pressure transducers in AISI 316, turbine flow meters with current output and the relevant software.

The adoption of the "IMPRESA 4.0" digital KIT allows the possibility of accessing significant tax advantages.



ROTOR FLOW SENSOR



PRESSURE TRANSDUCER

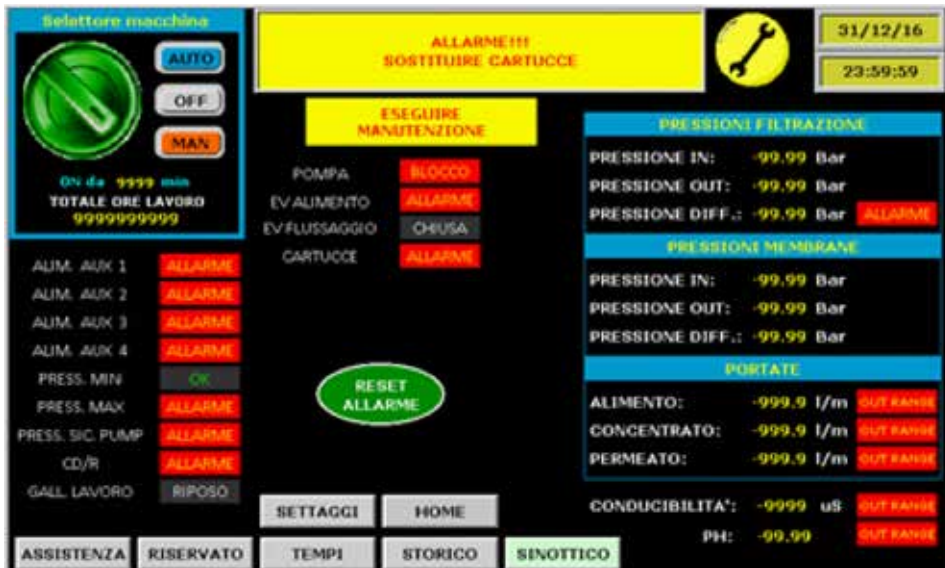

ROTOR FLOW SENSOR WITH BRACKET SOCKET

PARAMETERS OF KIT IMPRESA DIGITALE 4.0



BATTERY OF PRESSURE TRANSDUCERS

SETTINGS OF KIT IMPRESA DIGITALE 4.0